

PLEASE CHECK WWW.MOLEX.COM FOR LATEST PART INFORMATION

Part Number: [0192210399](#)
Status: **Active**
Description: Compression Style Ring Tongue Terminal for 2 AWG Wire, Stud Size 1/2", Un-Plated, Wide Pad

Documents:

[Drawing \(PDF\)](#) [RoHS Certificate of Compliance \(PDF\)](#)

Agency Certification

CSA LR18689
 UL E32244

General

Product Family Ring and Spade Terminals
 Series [19221](#)
 Comments Heavy Duty
 Crimp Quality Equipment Yes
 Mil-Spec N/A
 Product Name Battery Cable Lug
 Type Ring

Physical

Barrel Type Closed
 Insulation None
 Material - Plating Mating Tin
 Packaging Type Bag
 Stud Size 1/2" (M12)
 Termination Interface: Style Crimp or Compression
 Wire Insulation Diameter N/A
 Wire Size AWG 2
 Wire Size mm² 26.60 - 42.40

Material Info

Old Part Number BCL-212-WP

Reference - Drawing Numbers

Sales Drawing SD-19221-010

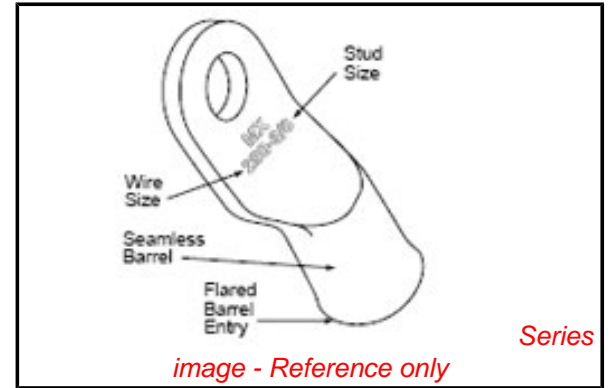

EU RoHS

ELV and RoHS Compliant
REACH SVHC
 Not Reviewed
Halogen-Free Status
 Not Reviewed

China RoHS



Need more information on product environmental compliance?

Email productcompliance@molex.com
 For a multiple part number RoHS Certificate of Compliance, [click here](#)

Please visit the [Contact Us](#) section for any non-product compliance questions.

Search Parts in this Series

[19221Series](#)

Application Tooling | [FAQ](#)

Tooling specifications and manuals are found by selecting the products below. Crimp Height Specifications are then contained in the Application Tooling Specification document.

Global

| Description | Product # |
|--|----------------------------|
| Putt Pump Dieless Head System | 0192860065 |
| Manual tool for Crimping non-insulated 8AWG thru 4/0 Terminals | 0192940008 |
| Manual Putt Pump Hydraulic System, Die set required | 0192860117 |
| Die Set (large) for the HHLS Hydraulic Crimper | 0192900010 |

This document was generated on 04/12/2010

PLEASE CHECK WWW.MOLEX.COM FOR LATEST PART INFORMATION

| | 13 | 12 | 11 | 10 | 9 | 8 | 7 | 6 | 5 | 4 | 3 | 2 | 1 | | | | | |
|---|--------------------------|----------------------|---------------------------|---------------------------|------------------------|---------------------------|-------------------------|-------------------------|------------|------------|----------------|--------------|---------------|--------------|--------------|-------------|-------------|---|
| J | UNPLATED MATERIAL NUMBER | UNPLATED ENG. NUMBER | UNPLATED MAT. NO. ON TAPE | UNPLATED ENG. NO. ON TAPE | PLATED MATERIAL NUMBER | PLATED ENGINEERING NUMBER | PLATED MAT. NO. ON TAPE | PLATED ENG. NO. ON TAPE | SEE DETAIL | STUD SIZE | AWG WIRE RANGE | "S" | "L" | "W" | "C" | "B" | "T" | J |
| | 1922 10451 | BCL-410 | --- | --- | 1922 10452 | BCL-410-PL | --- | --- | --- | 10/(4.83) | 4 | .214/(5.45) | 1.500/(38.10) | .531/(13.49) | .429/(10.90) | .286/(7.26) | .080/(2.03) | |
| | 1922 10404 | BCL-414 | --- | --- | 1922 10230 | BCL-414-PL | --- | --- | --- | 1/4/(6.4) | 4 | .278/(7.06) | 1.500/(38.10) | .531/(13.49) | .429/(10.90) | .286/(7.26) | .080/(2.03) | |
| | 1922 10405 | BCL-4516 | --- | --- | 1922 10231 | BCL-4516-PL | 1908 20025 | BCL-4516-PLT | D | 5/16/(7.9) | 4 | .340/(8.64) | 1.500/(38.10) | .531/(13.49) | .429/(10.90) | .286/(7.26) | .080/(2.03) | |
| | 1922 10461 | BCL-4516-WP | --- | --- | 1922 10460 | BCL-4516-WP-PL | --- | --- | --- | 5/16/(7.9) | 4 | .340/(8.64) | 1.531/(38.89) | .625/(15.88) | .397/(10.08) | .286/(7.26) | .080/(2.03) | |
| | 1922 10383 | BCL-438 | --- | --- | 1922 10232 | BCL-438-PL | 1908 20026 | BCL-438-PLT | E | 3/8/(9.5) | 4 | .400/(10.16) | 1.500/(38.10) | .531/(13.49) | .429/(10.90) | .286/(7.26) | .080/(2.03) | |
| | 1922 10458 | BCL-438-WP | --- | --- | 1922 10456 | BCL-438-WP-PL | 1908 20027 | BCL-438-WP-PLT | E | 3/8/(9.5) | 4 | .400/(10.16) | 1.531/(38.89) | .625/(15.88) | .397/(10.08) | .286/(7.26) | .080/(2.03) | |
| | 1922 10459 | BCL-438-XWP | --- | --- | 1922 10457 | BCL-438-XWP-PL | --- | --- | --- | 3/8/(9.5) | 4 | .400/(10.16) | 1.688/(42.88) | .766/(19.46) | .444/(11.28) | .286/(7.26) | .100/(2.54) | |
| I | 1922 10453 | BCL-412 | --- | --- | 1922 10454 | BCL-412-PL | --- | --- | --- | 1/2/(12.7) | 4 | .520/(13.21) | 1.688/(42.88) | .766/(19.46) | .444/(11.28) | .286/(7.26) | .100/(2.54) | I |
| | 1922 10419 | BCL-214 | --- | --- | 1922 10418 | BCL-214-PL | 1908 20001 | BCL-214-PLT | C | 1/4/(6.4) | 2 | .278/(7.06) | 1.625/(41.28) | .625/(15.88) | .437/(11.10) | .336/(8.53) | .095/(2.41) | |
| | 1922 10400 | BCL-2516 | --- | --- | 1922 10233 | BCL-2516-PL | 1908 20002 | BCL-2516-PLT | C | 5/16/(7.9) | 2 | .340/(8.63) | 1.625/(41.28) | .625/(15.88) | .437/(11.10) | .336/(8.53) | .095/(2.41) | |
| | 1922 10380 | BCL-238 | --- | --- | 1922 10235 | BCL-238-PL | --- | --- | --- | 3/8/(9.5) | 2 | .400/(10.16) | 1.625/(41.28) | .625/(15.88) | .437/(11.10) | .336/(8.53) | .095/(2.41) | |
| | 1922 10564 | BCL-238-WP | --- | --- | 1922 10565 | BCL-238-WP-PL | --- | --- | --- | 3/8/(9.5) | 2 | .278/(7.06) | 1.750/(44.45) | .750/(19.05) | .474/(12.04) | .336/(8.53) | .095/(2.41) | |
| | 1922 10399 | BCL-212-WP | --- | --- | 1922 10236 | BCL-212-WP-PL | --- | --- | --- | 1/2/(12.7) | 2 | .520/(13.21) | 1.750/(44.45) | .750/(19.05) | .474/(12.04) | .336/(8.53) | .095/(2.41) | |
| H | 1922 10594 | BCL-110 | --- | --- | 1922 10595 | BCL-110-PL | --- | --- | --- | #10/(4.83) | 1 | .214/(5.45) | 1.718/(43.64) | .656/(16.66) | .446/(11.33) | .360/(9.14) | .100/(2.54) | H |
| | 1922 10421 | BCL-114 | --- | --- | 1922 10420 | BCL-114-PL | --- | --- | --- | 1/4/(6.4) | 1 | .278/(7.06) | 1.718/(43.64) | .656/(16.66) | .446/(11.33) | .360/(9.14) | .100/(2.54) | |
| | 1922 10396 | BCL-1516 | --- | --- | 1922 10237 | BCL-1516-PL | --- | --- | --- | 5/16/(7.9) | 1 | .340/(8.63) | 1.718/(43.64) | .656/(16.66) | .446/(11.33) | .360/(9.14) | .100/(2.54) | |
| | 1922 10378 | BCL-138 | --- | --- | 1922 10238 | BCL-138-PL | --- | --- | --- | 3/8/(9.5) | 1 | .400/(10.16) | 1.718/(43.64) | .656/(16.66) | .446/(11.33) | .360/(9.14) | .100/(2.54) | |
| | 1922 10580 | BCL-138-WP | --- | --- | 1922 10581 | BCL-138-WP-PL | --- | --- | --- | 3/8/(9.5) | 1 | .400/(10.16) | 1.844/(46.84) | .750/(19.05) | .474/(12.04) | .360/(9.14) | .100/(2.54) | |
| | 1922 10395 | BCL-112 | --- | --- | 1922 10239 | BCL-112-PL | --- | --- | --- | 1/2/(12.7) | 1 | .520/(13.21) | 1.844/(46.84) | .750/(19.05) | .474/(12.04) | .360/(9.14) | .100/(2.54) | |

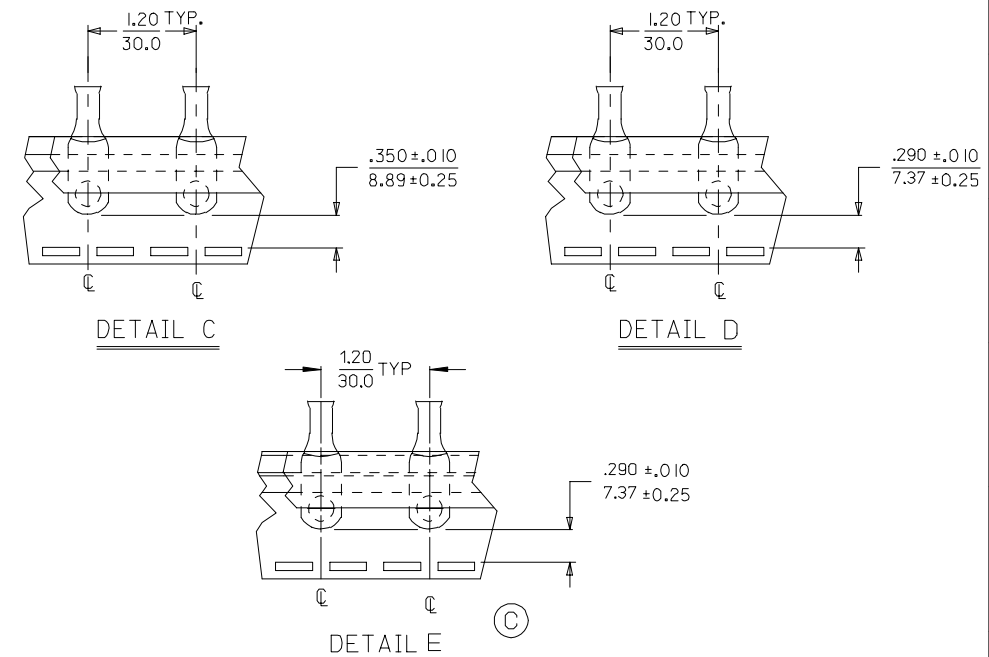
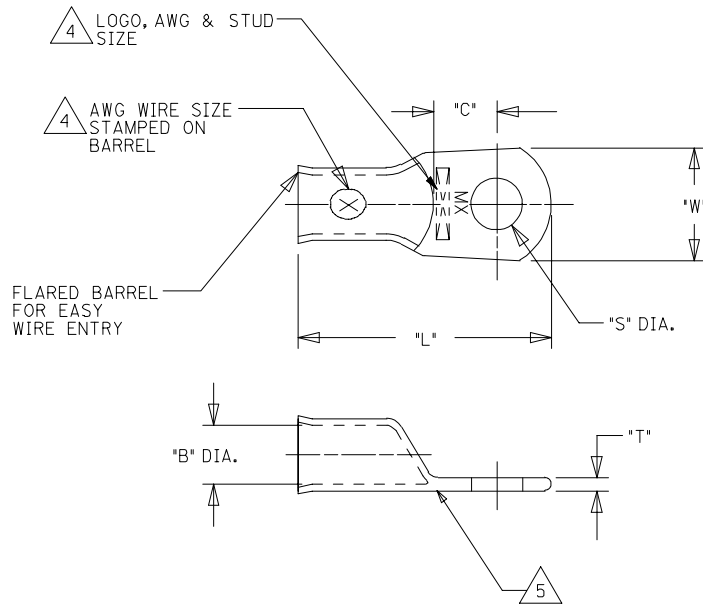

- NOTES:
- FOR INSPECTION SIGHT HOLE, PLEASE CONSULT FACTORY.
 - OTHER STUD SIZES MAY BE AVAILABLE, PLEASE CONSULT FACTORY.
 - MATERIAL: COPPER
PLATING: TIN
 - MARKINGS CAN BE AT EITHER LOCATION SHOWN.
 - IF TONGUE IS TO BE BENT AT ANY ANGLE, IT MUST BE BENT AROUND A RADIUS ONE HALF THE TONGUE THICKNESS.

| | | | | | | |
|--|--|---|---|--|--------------------|------------------------|
| ADDED DETAIL E EC NO: ETC2006-0005 DR: WILLSHADECK 2005/11/23 CHKD: ROSS 2005/11/23 APPR: JPAWLICK 2005/11/23 REVISIONS DESCRIPTION | QUALITY SYMBOLS | GENERAL TOLERANCES (UNLESS SPECIFIED) | DIMENSION STYLE | SCALE | DESIGN UNITS | THIRD ANGLE PROJECTION |
| | $\nabla=0$ $\nabla=0$ | mm INCH | IN/MM | --- | INCH | |
| | 4 PLACES ± --- ± --- 3 PLACES ± --- ± --- 2 PLACES ± --- ± --- 1 PLACE ± --- ± --- ANGULAR ± --- ° | DRAWN BY: BE DATE: 06/26/02 CHECKED BY: HB DATE: 06/26/02 APPROVED BY: RD DATE: 06/26/02 | MATERIAL NO. SEE CHART | TITLE EYELET STYLE COPPER TERMINALS 4, 2, & 1 AWG LUGS | MOLEX INCORPORATED | SHEET NO. 1 OF 1 |
| | DRAFT WHERE APPLICABLE MUST REMAIN WITHIN DIMENSIONS | MATERIAL NO. SD-19221-010 | THIS DRAWING CONTAINS INFORMATION THAT IS PROPRIETARY TO MOLEX INCORPORATED AND SHOULD NOT BE USED WITHOUT WRITTEN PERMISSION | | | |